



TIRE SAFETY

*Everything
Rides on It*

Studies of tire safety show that maintaining proper tire pressure, observing tire and vehicle load limits (not carrying more weight in your vehicle than your tires or vehicle can safely handle), avoiding road hazards, and inspecting tires for cuts, slashes, and other irregularities are the most important things you can do to avoid tire failure such as tread separation or blowout and flat tires. These actions along with other care and maintenance activities can also:

- ⦿ Improve vehicle handling;
- ⦿ Help protect you and others from avoidable breakdowns and crashes;
- ⦿ Improve fuel economy; and
- ⦿ Increase the life of your tires.

This booklet presents a comprehensive overview of tire safety, including information on the following topics:

- ⦿ Basic tire maintenance;
- ⦿ Uniform Tire Quality Grading System;
- ⦿ Fundamental characteristics of tires; and
- ⦿ Tire safety tips.

Use this information to make tire safety a regular part of your vehicle maintenance routine. Recognize that the time you spend is minimal compared with the inconvenience and safety consequences of a flat tire or other tire failure.

Safety First—Basic Tire Maintenance

Properly maintained tires improve the steering, stopping, traction, and load-carrying capability of your vehicle. Underinflated tires and overloaded vehicles are a major cause of tire failure. Therefore, as mentioned above, to avoid flat tires and other



types of tire failure, you should maintain proper tire pressure, observe tire and vehicle load limits, avoid road hazards, and regularly inspect your tires.

Finding Your Vehicle's Recommended Tire Pressure and Load Limits

Tire information placards and vehicle certification labels contain information on tires and load limits. These labels indicate the vehicle manufacturer's information including:

- ⦿ Recommended tire size;
- ⦿ Recommended tire inflation pressure;
- ⦿ Vehicle capacity weight (VCW—the maximum occupant and cargo weight a vehicle is designed to carry); and
- ⦿ Front and rear gross axle weight ratings (GAWR—the maximum weight the axle systems are designed to carry).

Both placards and certification labels are permanently attached to the driver's side vehicle door edge or door post. You can also find the recommended tire pressure and load limit for your vehicle in the vehicle owner's manual.

Understanding Tire Pressure and Load Limits

Tire inflation pressure is the amount of air in the tire that provides it with load-carrying capacity and affects the overall performance of the vehicle. The tire inflation pressure is a number that indicates the amount of air pressure — measured in pounds per square inch (psi) — a tire requires to be properly inflated. (You will also find this number on the vehicle information placard expressed in kilopascals (kPa), which is the metric measure used internationally.)

Manufacturers of passenger vehicles and light trucks determine this number based on the vehicle's design load limit, that is, the greatest amount of weight a vehicle can safely carry and the vehicle's tire size. The proper tire pressure for your vehicle is referred to as the "recommended cold inflation pressure." (As you will read below, it is difficult to obtain the recommended tire pressure if your tires are not cold.)

Because tires are designed to be used on more than one type of vehicle, tire manufacturers list the "maximum permissible inflation pressure" on the tire sidewall. This number is the greatest amount of air pressure that should ever be put in the tire under normal driving conditions.

Remember, however, that the *vehicle* manufacturer, not the *tire* manufacturer, determines the correct tire pressure for the tires on your vehicle.

Checking Tire Pressure

It is important to check your vehicle's tire pressure at least once a month for the following reasons:

- ⦿ Most tires naturally lose air over time.
- ⦿ Tires can lose air suddenly if you drive over a pothole or other object or if you strike the curb when parking.
- ⦿ With radial tires, it is usually difficult to determine some levels of underinflation by visual inspection.

For convenience, buy a tire pressure gauge to keep in your vehicle. Gauges can be purchased at tire dealerships, auto supply stores, and other retail outlets.



The recommended tire inflation pressure that vehicle manufacturers provide reflects the proper psi when a tire is cold. The term “cold” does not relate to the outside temperature. Rather, a cold tire is one that has not been driven on for at least three hours. When you drive, your tires get warmer, causing the air pressure within them to increase. Therefore, to get an accurate tire pressure reading, you must measure tire pressure when the tires are cold or compensate for the extra pressure in warm tires.

Steps for Maintaining Proper Tire Pressure

Step 1: Locate the recommended tire pressure on the vehicle’s tire information placard, certification label, or in the owner’s manual.

Step 2: Record the tire pressure of all tires.

Step 3: If the tire pressure is too high in any of the tires, slowly release air by gently pressing on the tire valve stem with the edge of your tire gauge until you get to the correct pressure.

Step 4: If the tire pressure is too low, note the difference between the measured tire pressure and the correct tire pressure. These “missing” pounds of pressure are what you will need to add.

Step 5: At a service station, add the missing pounds of air pressure to each tire that is underinflated.

Step 6: Check all the tires to make sure they have the same air pressure (except in cases in which the front and rear tires have different recommended inflation pressures).

If you have been driving your vehicle and think that a tire is underinflated, fill it to the recommended cold inflation pressure indicated on your vehicle’s tire information placard or

certification label. While your tire may still be slightly underinflated due to the extra pounds of pressure in the warm tire, it is safer to drive with air pressure that is slightly lower than the vehicle manufacturer's recommended cold inflation pressure than to drive with a significantly underinflated tire. Since this is a temporary fix, don't forget to recheck and adjust the tire's pressure when you can obtain a cold reading.



Tire Size

To maintain tire safety, buy new tires that are the same size as the vehicle's original tires or another size recommended by the vehicle manufacturer. Look at the tire information placard, the owner's manual, or the sidewall of the tire you are replacing to find this information. If you have any doubt about the correct size to choose, consult with the tire dealer.

Tire Tread

The tire tread provides the gripping action and traction that prevent your vehicle from slipping or sliding, especially when the road is wet or icy. In general, tires are not safe and should be replaced when the tread is worn down to $\frac{2}{32}$ of an inch.



Tires have built-in treadwear indicators that let you know when it is time to replace your tires. These indicators are raised sections spaced intermittently in the bottom of the tread grooves.



When they appear “even” with the outside of the tread, it is time to replace your tires. Another method for checking tread depth is to place a penny in the tread with Lincoln’s head upside down and facing you. If you can see the top of Lincoln’s head, you are ready for new tires.

Tire Balance and Wheel Alignment

To avoid vibration or shaking of the vehicle when a tire rotates, the tire must be properly balanced. This balance is achieved by positioning weights on the wheel to counterbalance heavy spots on the wheel-and-tire assembly. A wheel alignment adjusts the angles of the wheels so that they are positioned correctly relative to the vehicle’s frame. This adjustment maximizes the life of your tires and prevents your car from veering to the right or left when driving on a straight, level road. These adjustments require special equipment and should be performed by a qualified technician.

Tire Rotation

Rotating tires from front to back and from side to side can reduce irregular wear (for vehicles that have tires that are all the same size). Look in your owner’s manual for information on how frequently the tires on your vehicle should be rotated and the best pattern for rotation.

Be aware that some tires may have a one-directional tread pattern that requires them to be



operated in one direction only. Therefore, these tires should only be rotated from front to back on the same side of the vehicle.

A Tire Rotation Example

For maximum mileage, rotate your tires every 5,000 miles. Follow the correct rotation patterns.

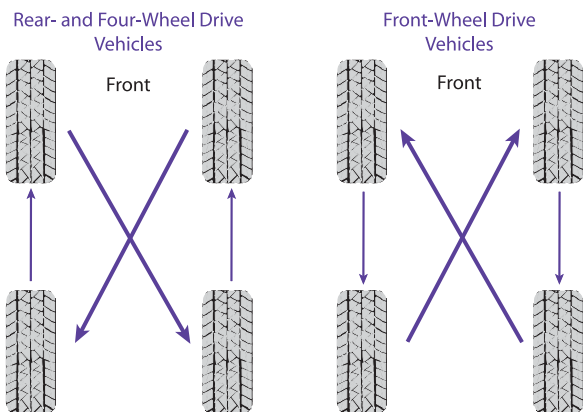

Tire Repair

The proper repair of a punctured tire requires a plug for the hole and a patch for the area inside the tire that surrounds the puncture hole. Punctures through the tread can be repaired if they are not too large, but punctures to the sidewall should not be repaired. Tires must be removed from the rim to be properly inspected before being plugged and patched.

Uniform Tire Quality Grading System

To help consumers compare a passenger car tire's treadwear rate, traction performance, and temperature resistance, the Federal government requires tire manufacturers to grade tires in these three areas. This grading system, known as the Uniform Tire Quality Grading System, provides guidelines for making relative comparisons when buying new tires. You also can use this information to inquire about the quality of tires placed on new vehicles.



Treadwear Grade

The treadwear grade is an indication of a tire's relative wear rate. The higher the treadwear number is, the longer it should take for the tread to wear down.

For example, a tire graded 400 should last twice as long as a tire graded 200.

Traction Performance Grade

The traction grade indicates a tire's ability to stop on wet pavement. A higher graded tire should allow you to stop your car on wet roads in a shorter distance than a tire with a lower grade. Traction is graded from highest to lowest as AA, A, B, and C.

Temperature Resistance Grade

The temperature resistance grade indicates a tire's resistance to heat. The temperature grade is for a tire that is inflated properly and not overloaded. Excessive speed, underinflation or excessive loading, either separately or in combination, can cause heat build-up and possible tire failure. From highest to lowest, a tire's resistance to heat is graded as A, B, or C.

Although this grading system is very helpful when buying new tires, it is not a safety rating or guarantee of how well a tire will perform or how long it will last. Other factors such as personal driving style, type of car, quality of the roads, and tire maintenance habits have a significant influence on your tire's performance and longevity.

Tire Fundamentals

Federal law requires tire manufacturers to place standardized information on the sidewall of all tires. This information identifies and describes the fundamental characteristics of the tire and

also provides a tire identification number for safety standard certification and in case of a recall. Examples of key information found on passenger vehicle and light truck tires follow.

Passenger Car Tires

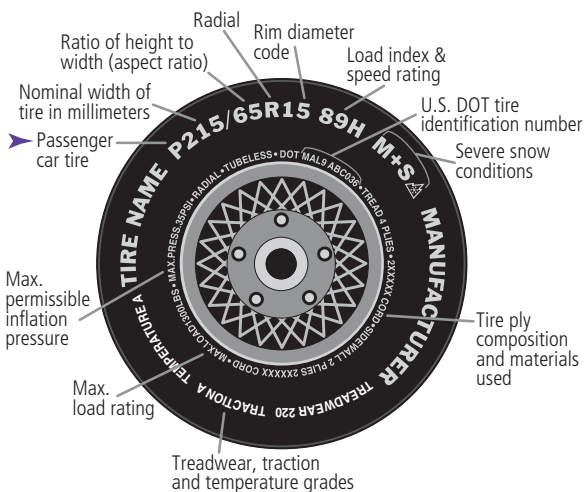

Sidewall Outer Circle

Passenger Car Tire

The “P” indicates the tire is for passenger cars and other light vehicles.

Nominal Width

This three-digit number gives the width in millimeters of the tire from sidewall edge to sidewall edge. In general, the larger the number, the wider the tire.

Aspect Ratio

This two-digit number, known as the aspect ratio, gives the tire’s ratio of height to width. Numbers of 70 or lower indicate a short sidewall for improved steering response and better overall handling on dry pavement.

Radial

The “R” stands for radial. Radial ply construction of tires has been the industry standard for the past 30 years.



Rim Diameter Code

This two-digit number is the wheel or rim diameter in inches. If you change your wheel size, you will have to buy new tires to match the new wheel diameter.

Load Index

This two- or three-digit number is the tire's load index. It is a measurement of how much weight each tire can support. You may find this information in your owner's manual. If not, contact a local tire dealer. *Note:* You may not find this information on all tires because it is not required by law.

Speed Rating

The speed rating denotes the maximum speed at which a tire is designed to be driven. The ratings range from 99 mph to 186 mph. These ratings are listed below. *Note:* You may not find this information on all tires because it is not required by law.

Q	99 mph	H	130 mph
R	106 mph	V	149 mph
S	112 mph	W	168 mph*
T	118 mph	Y	186 mph*
U	124 mph		

* For tires with a maximum speed capability over 149 mph, tire manufacturers sometimes use the letters ZR. For those with a maximum speed capability over 186 mph, tire manufacturers must use the letters ZR.

Severe Snow Conditions

The “M+S” or “M/S” indicates that the tire has some mud and snow capability. Most radial tires have these markings; hence, they have some mud and snow capability.



In some heavy snow areas, local governments may require true snow tires, those with very deeply cut tread. These tires should only be used in pairs or placed on all four wheels. Make sure you buy snow tires that are the same size as the other tires on your vehicle.

Sidewall Inner Circle

U.S. DOT Tire Identification Number

This begins with the letters “DOT” and indicates that the tire meets all Federal standards. The next two numbers or letters are the plant code where it was manufactured, and the last four digits represent the week and year the tire was built. For example, the digits 3197 means the 31st week of 1997. The other numbers are marketing codes used at the manufacturer’s discretion. This information is used to contact consumers if a tire defect requires a recall.

Tire Ply Composition and Materials Used

The number of plies indicates the number of layers of rubber-coated fabric in the tire. In general, the greater the number of plies, the more weight a tire can support. Tire manufacturers also must indicate the materials in the tire, which include steel, nylon, polyester, and others.

Maximum Load Rating

This number indicates the maximum load in kilograms and pounds that can be carried by the tire.

Maximum Permissible Inflation Pressure

This number is the greatest amount of air pressure that should ever be put in the tire under normal driving conditions.



Light-Truck Tires

Tires for light trucks have other markings besides those found on the sidewalls of passenger tires.

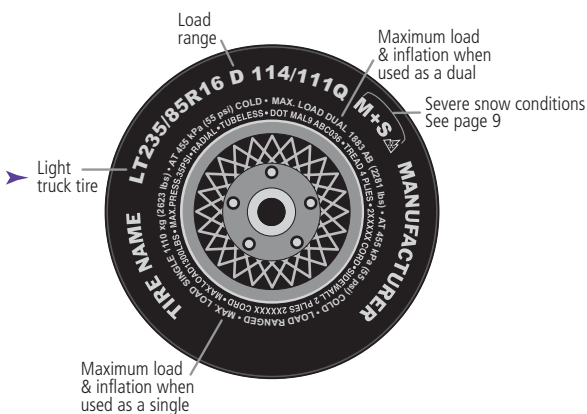

Light Truck Tire

The “LT” indicates the tire is for light trucks.

Load Range

This information identifies the tire’s load-carrying capabilities and its inflation limits.

Maximum Load Dual

This information indicates the maximum load and tire pressure when the tire is used as a dual, that is, when four tires are put on each rear axle (a total of six or more tires on the vehicle).*

Maximum Load Single

This information indicates the maximum load and tire pressure when the tire is used as a single.*

* Maximum load is presented in kilograms and pounds (kg/lbs). Maximum tire pressure is presented in kilopascals and pounds per square inch (kPa/psi) for when the tire is cold.

Tire Safety Tips

Preventing Tire Damage

- ⦿ Slow down if you have to go over a pothole or other object in the road.
- ⦿ Do not run over curbs or foreign objects in the roadway, and try not to strike the curb when parking.

Tire Safety Checklist

- ✓ Check tire pressure regularly (at least once a month), including the spare.
- ✓ Inspect tires for cracks, foreign objects, uneven wear patterns on the tread, or other signs of wear or trauma.
- ✓ Remove bits of glass and other foreign objects wedged in the tread.
- ✓ Make sure your tire valves have valve caps.
- ✓ Check tire pressure before going on a long trip.
- ✓ Do not overload your vehicle. Check the tire information placard or owner's manual for the maximum recommended load for the vehicle.
- ✓ If you are towing a trailer, remember that some of the weight of the loaded trailer is transferred to the towing vehicle.

For more information,
visit www.nhtsa.gov or call 888-327-4236

